

1979 - 1989 MUSTANG CASTER/CAMBER PLATE INSTALLATION INSTRUCTIONS

P/N 340005

INSTALLATION:

1. Raise front of car with jack and support with jack stands.
 2. Remove front wheels and disconnect sway bar end links.
 3. Place jack under A-arm and raise up to compress spring and release tension on strut.
 4. Remove upper strut retaining nut and strut mount plate retaining bolts. Remove upper strut bushing. (Can be reused as a bumpstop on the strut shaft if required.)
 5. Lower jack to allow strut to drop beneath strut tower. Use diagonal cutters to remove clamp holding OEM dust boot to OEM strut mount (from inside the wheel well.) Use a utility knife to cut the dust boot lengthwise and remove dust boot.
 6. Raise A-arm with jack until strut shaft is ~2 inches through the strut tower hole. Slide OEM upper strut bushing (tapered side down) onto shaft.
- Two different stepped strut spacers are included to optimize strut travel for most applications. Spacers should be positioned so the strut is close to being centered in its travel at ride height. This can be checked by measuring the compressed and extended lengths of the strut and comparing this average to the position of the strut at ride height. Stock applications use the longer spacer (11) on bottom and shorter (13) on top. For most applications with a lower than stock ride height the short spacer should be placed on bottom with the long spacer on top. Check for adequate hood clearance after installation.
7. Install Racecraft Inc. caster camber plate on struts as shown below. If coil over springs are not being utilized slide the non-step spacer (10) onto the shaft. Slide desired lower step spacer onto strut shaft and insert shaft into bearing. Slide upper step spacer on shaft and tighten strut retaining nut. Make sure spacers are properly inserted into spherical bearing!
 8. Adjust jack height until plate is ~1/2" above strut tower. Place 1/2" spacers between main plate and strut tower. From below, insert stud plate through strut tower slots. Loosely install hardware.
 9. Move plates through the full range of adjustment and check for tight spots. If tight spots exist, remove plates and open up strut tower slots with a file or die grinder.
 10. Position plates in a neutral alignment position and tighten all hardware securely.
 11. Reconnect sway bar end links and reinstall front wheels.

*** DO NOT DRIVE VEHICLE BEFORE BEING REALIGNED! ***

ITEM	DESCRIPTION	QTY
1	STRUT	1
2	ADJUSTING JAM NUT	1
3	SPRING SEAT NUT	1
4	12" COIL OVER SPRING	1
5	BUMP STOP	1
6	TOP SPRING SEAT	1
7	THRUST WASHER	2
8	THRUST BEARING	1
9	STRUT SEAT HAT	1
10	COILOVER SPACER	1
11	TALL STEP SPACER	1
12	CASTER CAMBER PLATE	1
13	SHORT STEP SPACER	1
14	STRUT NUT	1

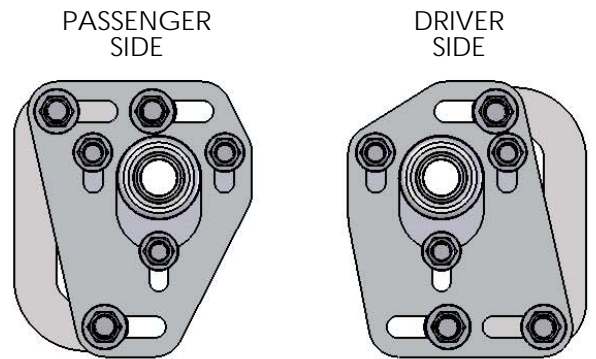

FRONT OF VEHICLE

